

REVISION			
Rev.	Description	Date	Approval
-	-	-	-

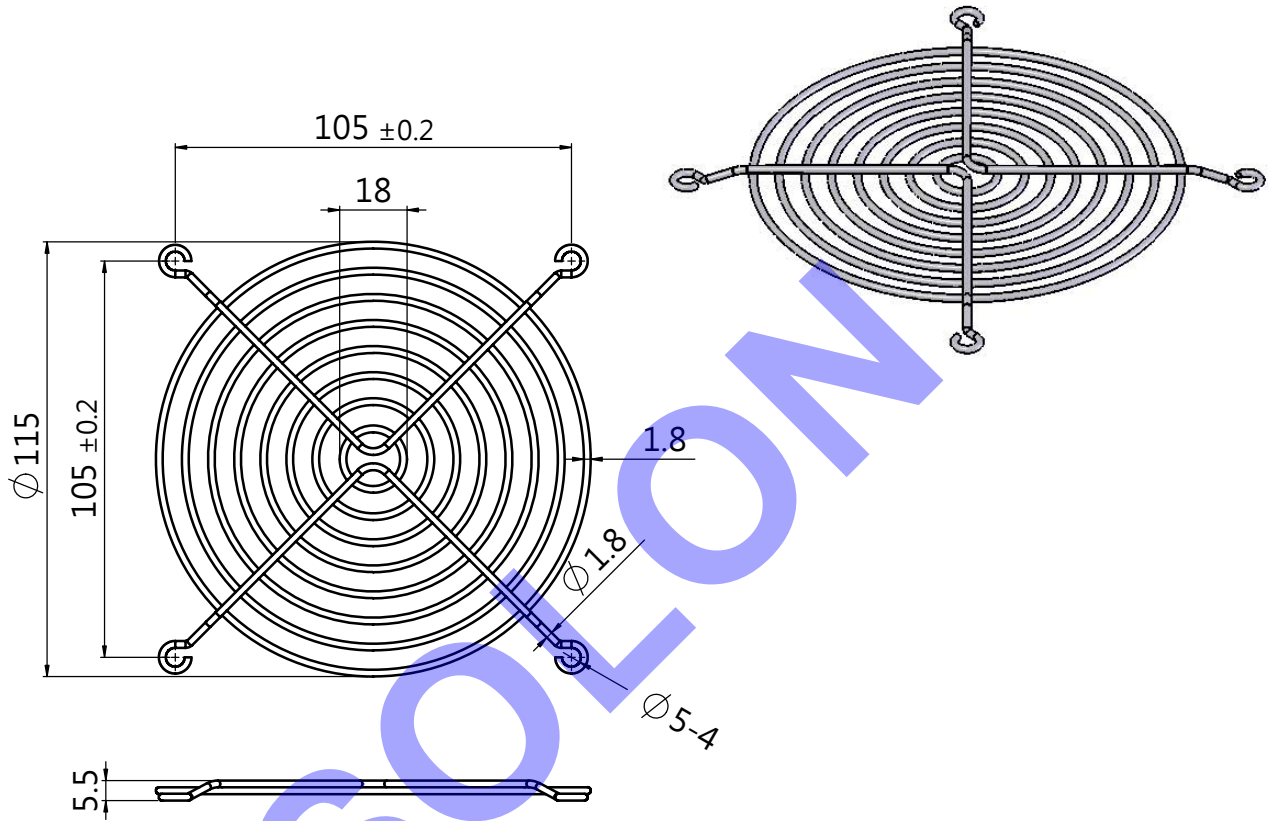

Notes:

- Material: C1008 Wire 低碳鋼線
- Finish: Bright Nickel Chromate plated 光澤鎳鉻電鍍
- Unless otherwise specified:
The tolerance is listed as follows:
X.X - ±0.10mm
X.XX - ±0.05mm
- Weight: 40 g
- Welding joint must to be withstand 88 lbs pull
焊接處需能承受88磅拉力



		DIMENSIONS ARE IN MILLIMETER		NAME	DATE	Model NO.		
		TOLERANCES:		DRAWN	Neafa	2013/6/21	SP-120	
		FRACTIONAL ±		CHECKED			Card NO.	
		ANGULAR: MACH ± BEND ±		ENG APPR.			HC-025	
		TWO PLACE DECIMAL ±		MFG APPR.			PART NO.	
		THREE PLACE DECIMAL ±		Q.A.			SP-0038-10	
		MATERIAL		PART NAME				
		FINISH		Metal Fan Guard				
NEXT ASSY	USED ON			SOLON		SIZE	DWG. NO.	REV.
APPLICATION		DO NOT SCALE DRAWING				A	SP-0038-10	0
				SCALE:1:5	WEIGHT:	SHEET 1 OF 1		

PROPRIETARY AND CONFIDENTIAL
THE INFORMATION CONTAINED IN THIS DRAWING IS THE SOLE PROPERTY OF SOLON ENTERPRISE CO., LTD. ANY REPRODUCTION IN PART OR AS A WHOLE WITHOUT THE WRITTEN PERMISSION OF SOLON ENTERPRISE CO., LTD. IS PROHIBITED.